



Liquid Waste Pump Out Units



Conde Liquid Waste Pump Out Units are complete self contained pumping machines designed to quickly turn a pickup or flatbed truck into a liquid waste pumping truck. Everything needed to begin immediate pumping is included. Simply bolt into place, and begin pumping! Available in either waste tank only or waste with fresh water system.

All Conde Liquid Waste Systems come standard with following features.

- Conde Super 6 pump with Honda Electric start engines.
- Removable Primary Shutoff built into tank to shut off vacuum when tank is full.
- Large capacity secondary moisture trap to protect pump.
- Pressure off-loading.
- 20' feet of 2" high quality suction hose with wand assembly.
- Vacuum and Pressure relief valves.
- Stainless steel vacuum/pressure combination gauge.
- Hose rack.
- Oil catch muffler for vacuum pump.
- Available in waste only tanks sized, 120, 235, 300, 400 & 500 gallons.
- Available in waste with fresh water tank in 300 waste, 100 water, and 400 waste, 100 water.

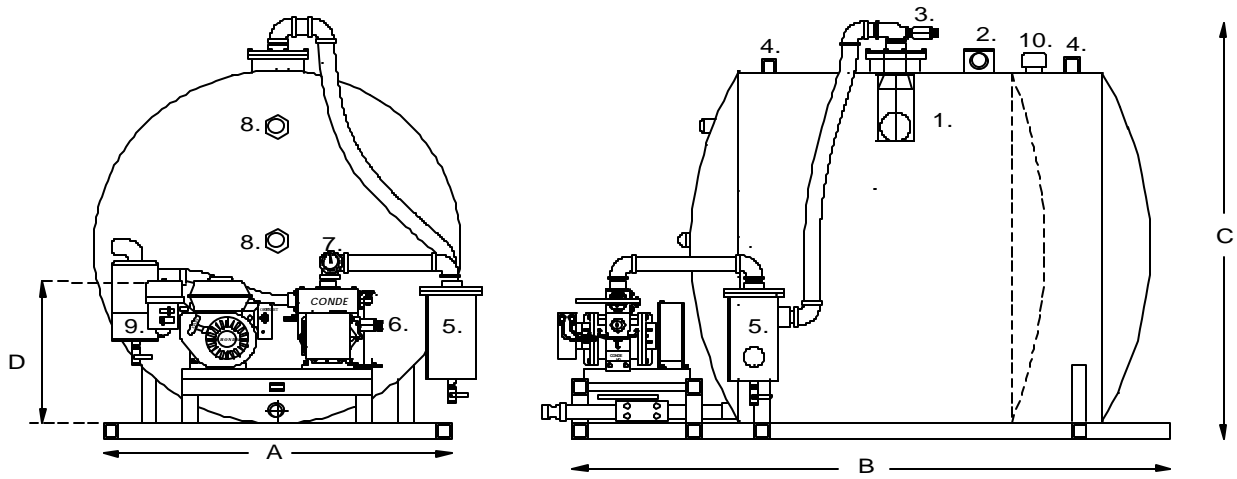

ITEM	120 GAL.	235 GAL.	300 GAL.	300/100	400 GAL.	400/100	500
A	30"	36"	42"	48"	48"	48"	48"
B	68-5/16"	71-1/8"	69-15/16"	76-3/4"	76-3/4"	83-3/4"	83-3/4"
C	39-3/8"	45-1/4"	51-1/4"	57-1/4"	57-1/4"	57-1/4"	57-1/4"
D	31"	31"	31"	31"	34"	34"	34"
WEIGHT	826 lbs.	878 lbs.	952 lbs.	1294 lbs.	1095 lbs.	1350 lbs.	1151 lbs.
PUMP UNIT	1.	1.	1.	1.	2.	2.	2.

1. Pump Unit, Conde Super 6, vacuum/pressure pump with 5.5 hp electric start Honda Engine.
2. Pump Unit, Conde Super 6, vacuum/pressure pump with 9.0 hp electric start Honda Engine

EQUIPMENT

ITEM	DESCRIPTION
1.	Primary Shut-Off, Fully Removable
2.	2" Waste Intake Assembly
3.	Pressure Relief Valve
4.	Lifting Eyes
5.	Aluminum Secondary Moisture Trap w/Drain
6.	Vacuum Relief Valve
7.	Liquid Filled Stainless Steel Vac/Press Gauge
8.	2" Sight Glass
9.	Oil Catch Muffler
10.	2" Fill Opening for Fresh Water

Waste & fresh water units feature spray down with the Power Pumps premium DC10 water pump system. The DC10 pump is rated for 20 gallons per minute. System includes pressure switch so that pump only runs when hose assembly is engaged. Additional toggle switch can turn entire water system off after use so there is no danger of draining battery if leak occurs. Quick turn vent makes priming water pump a breeze

Tank units are painted white. Other colors are available at an additional cost. Other options including larger vacuum pump units, diesel power, additional equipment, and special positioning of components also available at an additional cost.

800-367-0972

Fax: 315-363-0193

e-mail: pumps@westmoorlt.com

Westmoor Ltd.

P.O. Box 99
Sherrill, New York 13461