

OPERATING INSTRUCTIONS



**ROTARY VANE POSITIVE DISPLACEMENT
DRY-AIR PUMPS
VAPOR-OIL PUMPS**

CONGRATULATIONS!

You have purchased on oth the most dependable and thoroughly proven Rotary Positive Displacement Pumps available for vacuum or low pressure applications. When installed properly and used within stated and reasonable limits of load, it should provide years of satisfactory performance.

Please read and follow the suggestions for installation and maintenance given in this manual to obtain maximum performance and trouble free service. If you have any questions at any time, please feel free to contact our factory representative for helpful advise.

Westmoor, Ltd.

YOUR CONDE PUMP

MODEL # _____

SERIAL # _____

DATE PURCHASED _____

PURCHASED FROM _____

**PLEASE DIRECT QUESTIONS
OR COMMENTS TO:**

WESTMOOR LTD.
Conde Pump Division
906 West Hamilton Avenue

IMPORTANT

READ BEFORE INSTALLATION

OF THIS UNIT

WIRING

All wiring for the installation of this unit should be done by a licensed electrician according to National and Local Electrical Regulations.

SINGLE PHASE MOTOR UNITS

All single phase motors are wired for proper direction of rotation. Unless otherwise requested, motors are wired for low voltage service.

3-PHASE MOTOR UNITS

The belts have been removed from the unit to avoid running the air pump backwards in case of improper wiring. Wire the 3-phase motor to rotate in the same direction as the arrow on the Air Pump. **RUNNING THE AIR PUMP BACKWARDS MAY CAUSE VANE BREAKAGE.**

VAPOR OIL PUMPS

Use a High Detergent 10W-40 oil for all Conde Vapor Oil Pumps. Synthetic oil, like Mobil 1, is highly recommended. When starting a new Vapor Oil Pumps, fill oil reservoir above the fittings in which the oil wicks are inserted. This will give the Pump extra oil for the first two hours of operation. When refilling, fill to just below oil wicks.

Capacities:

Model 2.....	1 quart
Model 3.....	1 quart
Model 6.....	2 quarts

INSTALLATION INSTRUCTIONS CONTINUED

CHECK VALVE

A Horizontal check valve has been installed on all Dri-Air Pump Units to keep the pump from running backwards and to prevent siphoning liquid into the pump from wet applications.

VACCU RELIEF VALVE

The adjustable Vacuum Relief Valve is preset at 15 in Hg unless otherwise requested.

PRESSURE RELIEF VALVE

The adjustable Pressure Relief Valve is preset at 5 psig unless otherwise requested.

OPERATIONAL LIMITS

Max Vacuum (Continuous) 20" Hg

Max Vacuum (Intermittent) 25" Hg

Max Pressure (Continuous) 10 PSIG

Max Pressure (Intermittent) 15 PSIG

AIR PUMP UNIT

ASSEMBLY INSTRUCTIONS

All pipe thread fittings should be coated with a commercial pipe joint compound before assembly to prevent leaks.

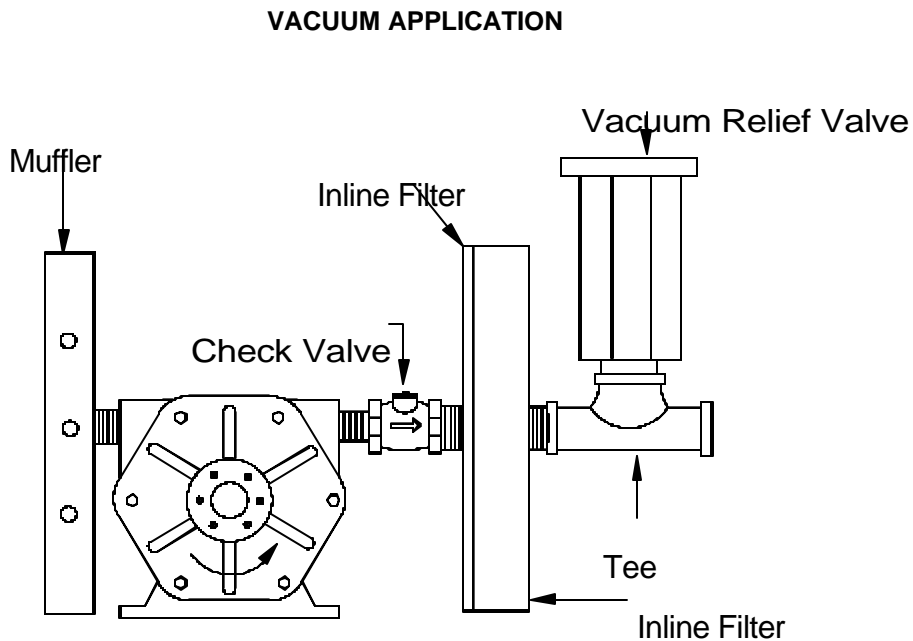
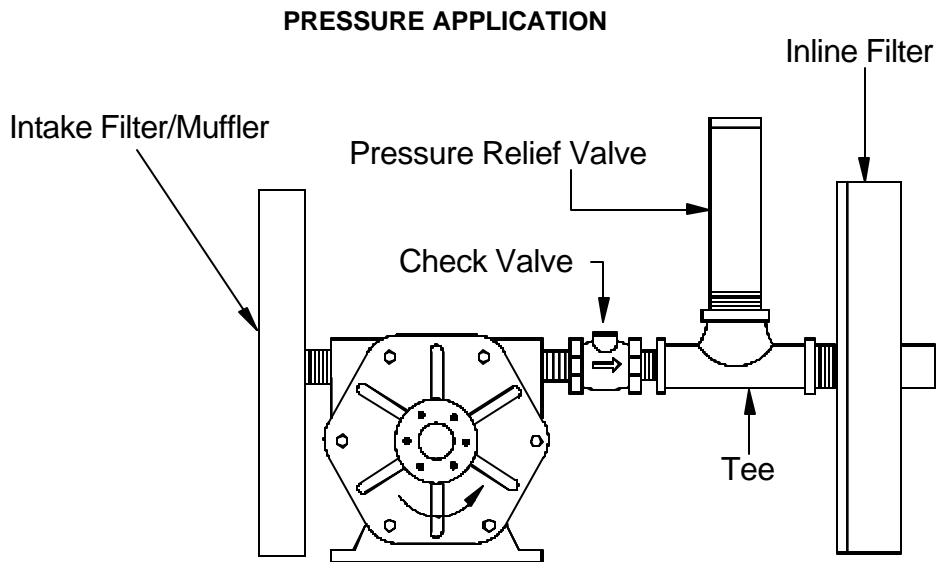

GENERAL MAINTENANCE

1. Clean filter media every 1000 hours of operation under clean operating conditions. For more severe conditions, clean or replace more frequently.
2. Adjust belt to 1/2" of free play at the center of the pulleys. Make the first adjustment after the first 24 hours of operation. Make any additional adjustments when necessary.
3. Lubricate motor or engine according to manufacturers recommendations that were supplied with the unit.
4. Fill oil reservoir in Vapor Oil Pumps to just below oil jet hole.
NEVER OIL DRY-AIR PUMPS.

STORAGE FOR CONDE DRY-AIR PUMPS

1. Disconnect air lines and pump fittings from the intake and exhaust ports of the air pump.
2. Plug the pump ports with commercial pipe plugs or the plastic plugs that were supplied with the unit.
3. Coat the pump shaft with a small amount of grease or oil to prevent rust buildup during storage.
4. Store the air pump in a cool dry place.

IMPORTANT RE-STARTING

When re-starting the air pump, turn the pump over by hand to be sure that shaft and rotor assembly spins freely within the pump

FLUSHING INSTRUCTIONS for CONDE VAPOR OIL PUMPS

It may be necessary to flush your Conde Vapor Oil Pump to remove any gum or varnish buildup inside the pump that cause the vanes to stick in their slots. This is a simple maintenance operation and should be the first step

Remove the oil tube at the oil reservoir.

Be sure the exhaust is directed away from the motor or engine.

User Kerosene or fuel oil for the flushing process. While the pump is running under vacuum, simply insert the oil tube into the kerosene and allow the pump to draw the fluid in. Alternately, let air into the tube with the kerosene. It can take up to a gallon of kerosene to clean the pump. **NEVER USE GASOLINE OR OTHER HIGHLY FLAMABLE LIQUID TO FLUSH OUT PUMP.**

After flushing, in the same manner draw in about 5 ounces of oil to complete the process.

INSTRUCTIONS FOR DISASSEMBLY & ASSEMBLY

DISASSEMBLY

Remove cooling fans.

Remove dowel pins, cap screws, bearing cover and shims.

Slide collar over shaft and tighten screws securely.

Screw the bolts into the three threaded holes in the opposite side of the pump that the collar is on. Turn the bolts alternating (no more than 1 turn at a time) until the endplate slides off the pump. This task can also be done with a pulley puller.

Remove the bearing from the endplate. (This can be done easily since the bearing is a slip fit in the endplate.)

Put the plate just removed back in place without the bearing then slide the collar over the shaft and tighten.

Remove the opposite endplate using the 3 bolts as previ-

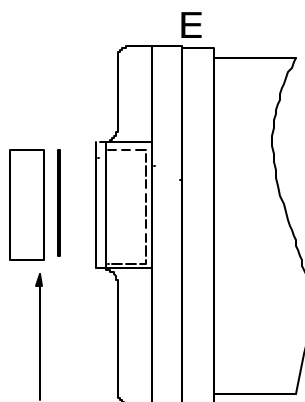
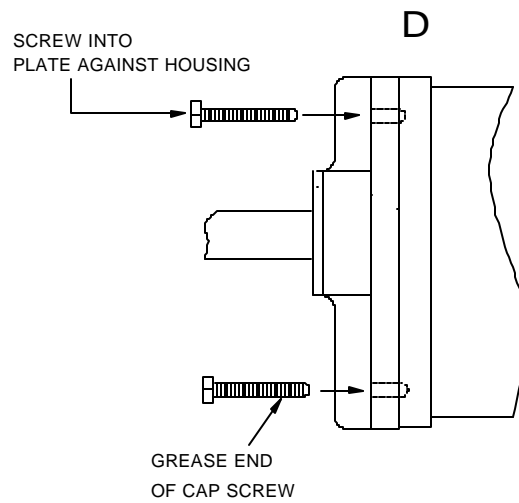
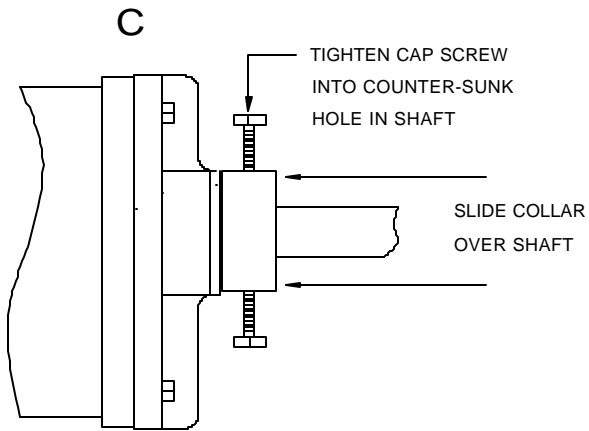
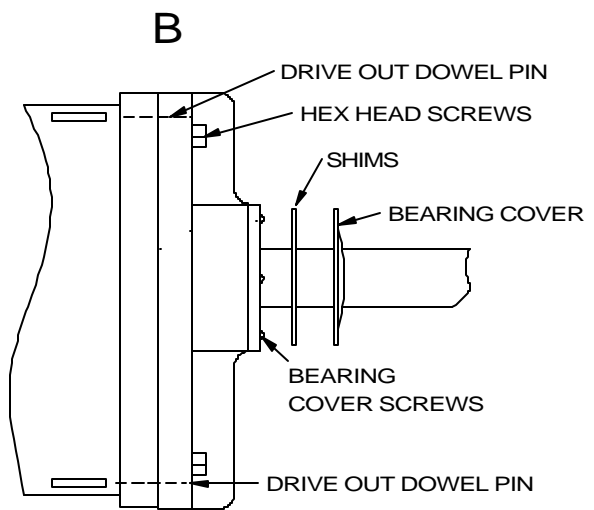
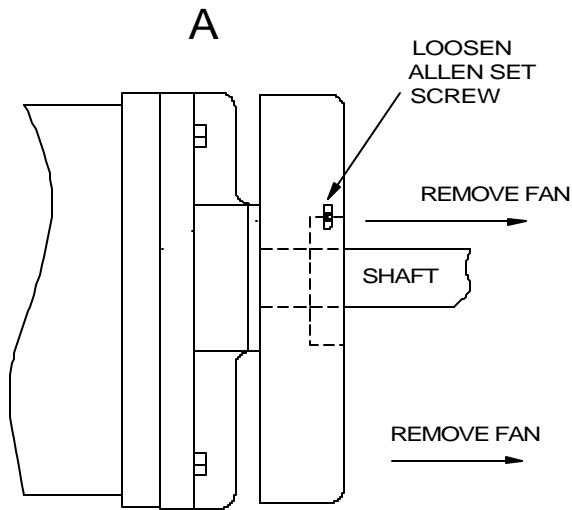

REMOVE BEARING & SLINGER DISK

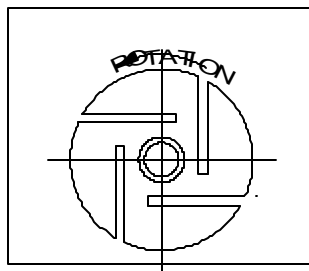
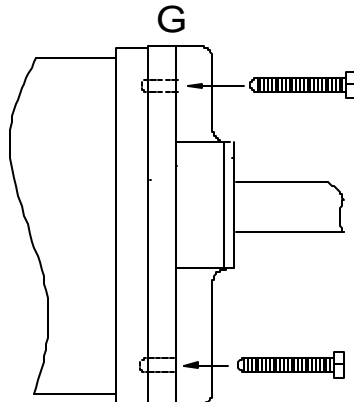
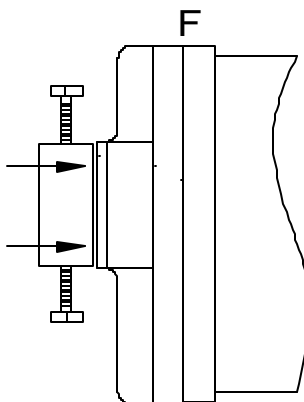

ASSEMBLY

1. Before assembly deburr all parts with a fine file. Determine correct rotor rotation (see drawing). Check the vane slots for free movement of vanes.
2. On Model 2 Pumps start assembly with side of housing that has the dowel pin holes on the left side of the housing. On Model ,3,6 & 12 start on side with dowel pin holes on the right. Note: dowel pin holes are always on the exhaust side of the pump.
On oil lubricated pumps press the shaft seal in place and place the paper gasket in position on the housing. Install the endplate with the six hex screws and finger tighten. Drive the 2 dowel pins in place, then tighten hex screws securely.
3. Insert rotor into housing according to rotor rotation and rotation arrows on the pump. (The pump must be assembled in the same position it was disassembled. The rotation cannot be changed.) Assemble the air pump in a vertical position. This will align the rotor with the endplates and housing.
4. Install the slinger over the shaft. (green disk)
5. Press bearing on the shaft using a bearing installation tool or arbor press. IMPORTANT – press on the inner race of bearing only. Pressing on the plastic seal may cause damage to roller bearings.
6. Invert pump assembly and install the vanes into the slots.
7. Install 2nd endplate as previously done, but do not tighten screws and leave dowel pins out. Install bearing and slinger.
8. Apply downward pressure to rotor shaft so that the rotor bottoms out on the 1st endplate, while pressure is applied, tighten hex screws evenly. Drive in dowel pins.
9. Shim the pump and install new bearing covers.

SEE NEXT PAGE FOR SHIMMING INSTRUCTIONS

SHIMMING INSTRUCTIONS

1. Turn rotor by hand to get a “feel” of how it turns when not binding on the endplates.
2. With a rubber mallet, hit one end of the rotor shaft to push rotor against the opposite endplate.
3. Insert shims and bearing cover on the side with the shaft you hit. Add enough shims so that the cover is flush with the endplate.
4. Screw in the bearing cover. NOTE: You can install three of the six screws on bearing covers with six screws equally spaced to save time.
5. Turn the pump by hand, and if the rotor feels like it is not binding at all, add more shims until a slight binding is felt.
6. Once this is done, remove .005” of these shims and re-install bearing cover with all screws, and set the remainder aside with the bearing cover. NOTE: Model 2 and Model 3 pumps require .0025” of shims to be removed and Model 12 pumps require .006” of shims to be removed.
7. Now hit the other end of the rotor shaft and repeat the above process of adding shims until binding occurs.
8. Remove .005” of these shims (.0025” on Model 2 and Model 3, .006” on Model 12) and re-install bearing cover with all screws.
9. Install shims and bearing cover on the other side that were previously set aside.
10. Now turn pump by hand. IMPORTANT: The pump should spin freely by hand when completed. If any binding occurs, repeat above process.
11. Reinstall cooling fans.

DRY-AIR PUMP PARTS

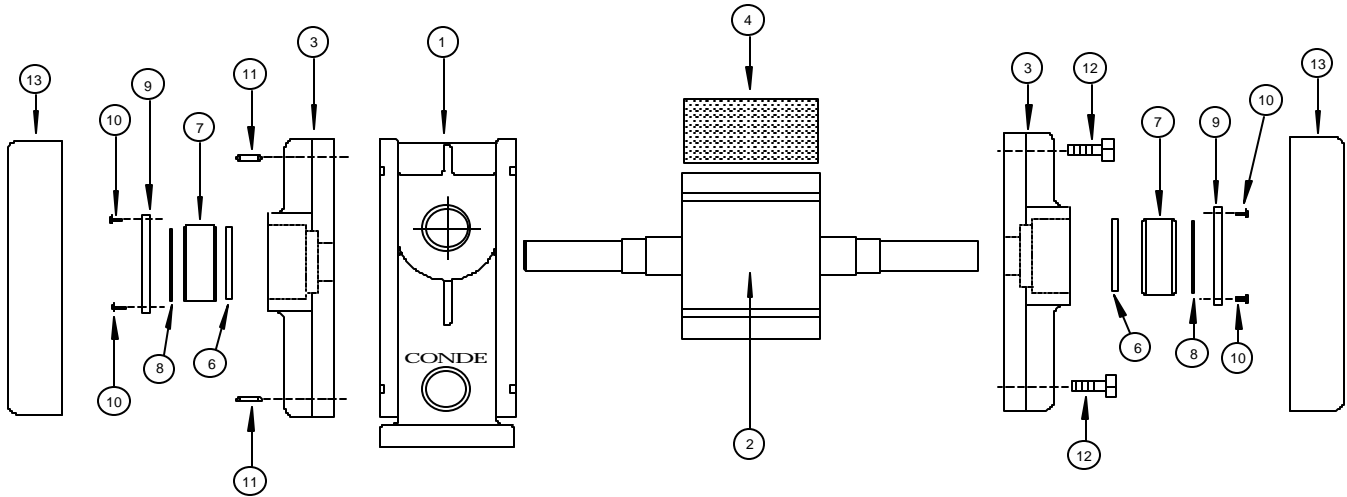

- | | | |
|----------------|------------------|-------------------------|
| 1. HOUSING | 6. SLINGER | 10. BEARING COVER SCREW |
| 2. ROTOR | 7. BEARING | 11. DOWEL PIN |
| 3. END PLATE | 8. SHIM | 12. HEX SCREW |
| 4. CARBON VANE | 9. BEARING COVER | 13. FAN |

VAPOR OIL PUMP PARTS

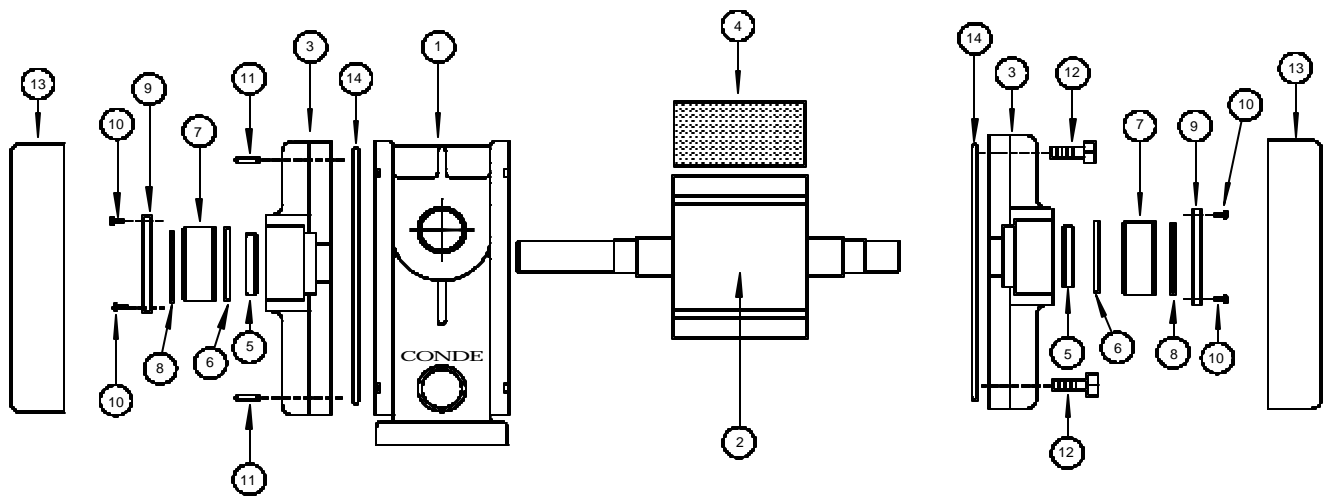

- | | | | |
|--------------|-------------|-------------------|---------|
| 1. HOUSING | 5. OIL SEAL | 9. BEARING | 13. FAN |
| 2. ROTOR | 6. SLINGER | 10. BEARING COVER | |
| 3. END PLATE | 7. BEARING | 11. DOWEL PIN | |
| 4. VANE | 8. SHIM | 12. HEX SCREW | |

LIMITED AMBIENT AIR ONLY WARRANTY STANDARD DRY AIR OR VAPOR OIL AIR PUMPS

Westmoor Ltd. warrants for a period of one (1) year from date of manufacture against defects in workmanship and material. During the period, Westmoor Ltd. will repair or replace and defective part free of charge, providing the product is returned, shipping prepaid, to our factory. Due to the extreme diversity of uses of the air pump, Westmoor Ltd. reserves the right to refuse warranty claims if, in the opinion of Westmoor Ltd. the installation or use of the pump exceeded the design capabilities. The pump is designed for ambient air intake only. Westmoor Ltd. does not warrant against minor leaks not affecting pump performance.

Owners responsibility include proving normal maintenance are required by Westmoor Ltd. This warranty does not apply (1) if the pump has been damaged due to improper use, neglect, accident, misuse, exposure to extremities of dryness or humidity (2) if the pump has been serviced or modified by other than Westmoor Ltd. authorized personnel.

No other warranty, expressed or implied, is given. The repair or replacement of the pump is your exclusive remedy. Any implied warranty of merchantability or fitness is limited to the duration of this written warranty. In no event shall Westmoor Ltd. be liable for consequential or incidental damages. Some states do not allow the exclusion or limitations of this warranty so the above exclusions or limitations may not apply to you. This warranty gives you specific legal rights, and you may have other rights which vary from state to state.